

MATLAB TOUR 2017

Novedades de las últimas
versiones de
MATLAB y Simulink

R2016b **R2017a**

Paz Tárrega
David Pérez



Application Breadth

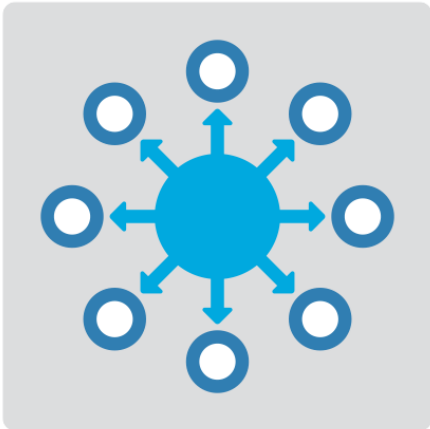

**Products for the
work you do**

Workflow Depth

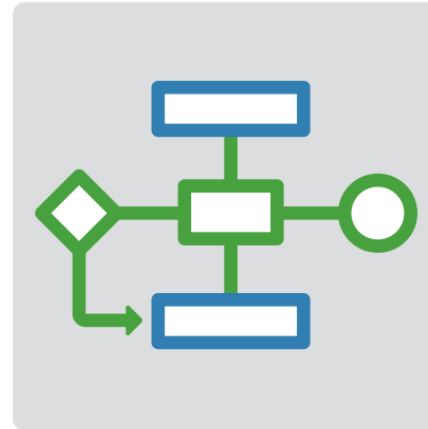

Platform Productivity



Machine Learning

“Learn” information directly from data without assuming a predetermined equation as a model

- Regression Learner app
 - Choose from multiple algorithms
 - Train and validate multiple models
 - Assess model performance, compare results, and choose the best model
- Code generation
 - Generate C code for predictive models that can be deployed directly to hardware devices

The screenshot displays the Regression Learner app interface. The main window shows a 'Response Plot' view with a toolbar containing options like 'New Session', 'Feature Selection', 'PCA', 'Complex Tree', 'Medium Tree', 'Simple Tree', 'All Trees', 'Advanced', 'Use Parallel', 'Train', 'Response Plot', 'Predicted vs. Actual Plot', 'Residuals Plot', and 'Export Model'. The 'Data Browser' shows a history of models, with the current model being a 'Tree [Draft]' with 7/7 features. The 'Original dataset: cartable' is displayed. A 'New Session' dialog box is open, showing the following steps:

Step 1: Select a table or matrix. A list of variables is shown, with 'cartable' selected.

Step 2: Select predictors and response. A table lists the selected variables:

Name	Type	Range	Import as
Acceleration	double	8 - 24.8	Predictor
Cylinders	double	3 - 8	Predictor
Displacement	double	68 - 455	Predictor
Horsepower	double	46 - 230	Predictor
Model_Year	double	70 - 82	Predictor
Weight	double	1613 - 5140	Predictor
Origin	char	7 unique	Predictor
MPG	double	9 - 46.6	Response

Step 3: Define validation method. The 'Cross-Validation' option is selected, with 'Cross-validation folds: 5 folds' set. The 'Holdout Validation' option is also visible, with 'Percent hold out: 25%'.

The 'Current Model' section shows 'Model 1: Draft' with the following settings:

- Model Type:** Preset: Complex Tree, Minimum leaf size: 4, Surrogate decision splits: Off
- Feature Selection:** All features used in the model, before PCA
- PCA:** PCA disabled

Deep Learning

R2016b R2017a

Apply deep learning to computer vision problems

- Configure and train models using object detection algorithms (*R-CNN, Fast R-CNN, Faster R-CNN*)
- Leverage pretrained models for transfer learning (*AlexNet, VGG-16, VGG-19*)
- Import models from Caffe
- Train networks using multiple GPUs (*including on Amazon EC2*)

Learn more at this session:
Machine Learning y Deep Learning con MATLAB

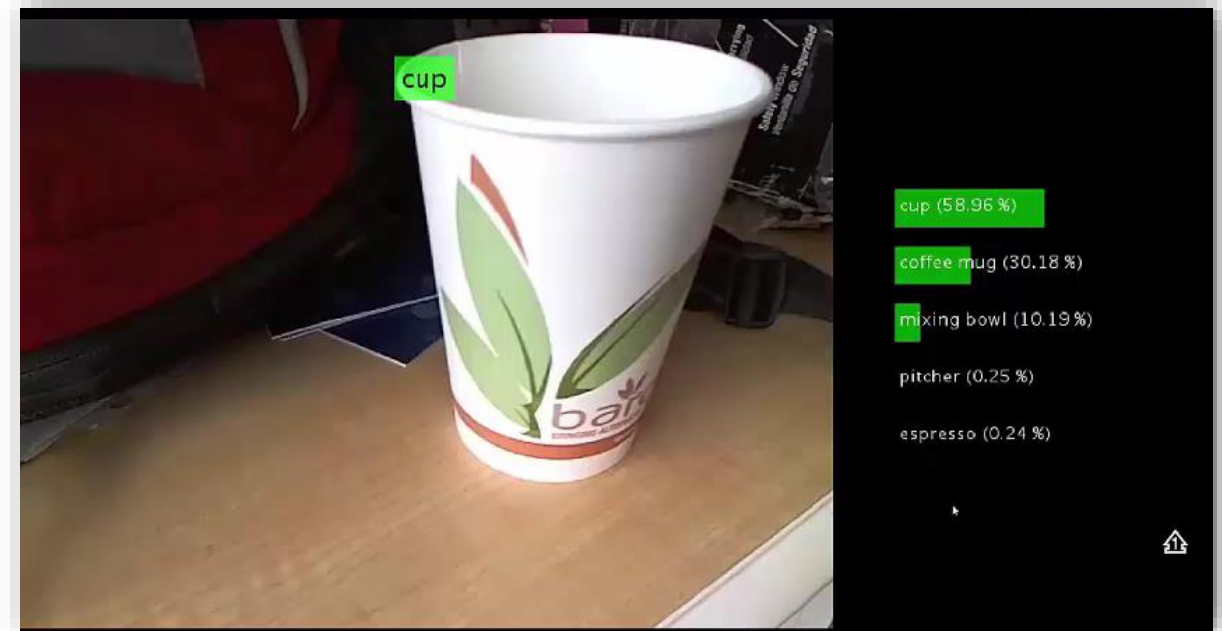

Autonomous Driving Systems

Design, simulate, and test ADAS and autonomous driving systems

- Algorithm development
 - Sensor Fusion
 - Computer Vision
 - Deep learning
- Visualization tools
- Testing and verification
 - Ground Truth Labeling App
 - Traffic scenario generation



More Modeling Domains Available

Model and simulation automotive powertrain systems

- Model gasoline, diesel, hybrid, and electric systems
- Simulate engine subsystems, transmission assemblies, battery packs

Faster Simulation

R2017a

Slower Simulation

Powertrain Blockset

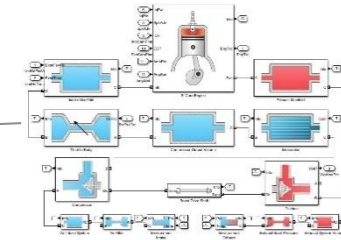

Simulink (ODE's)

Simscape (DAE's)

CAD Tools (PDE's)

Less Detail

More Detail

Design and test audio processing systems

R2016b

- Low-latency signal streaming
- Interactive parameter tuning
- Automatic generation of audio plugins

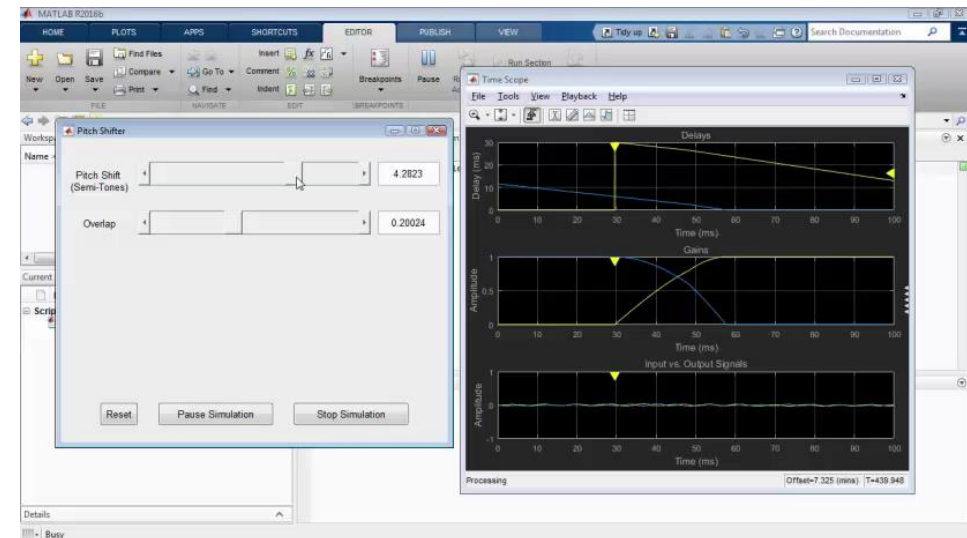

Application Breadth

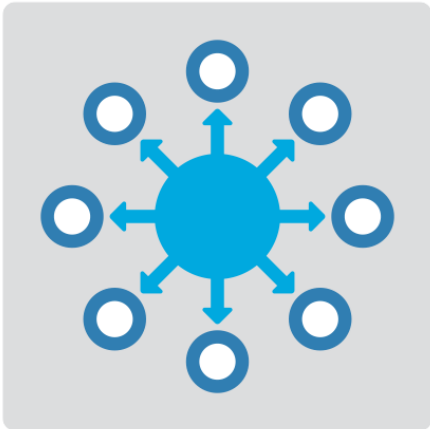

**Products for the
work you do**

Workflow Depth

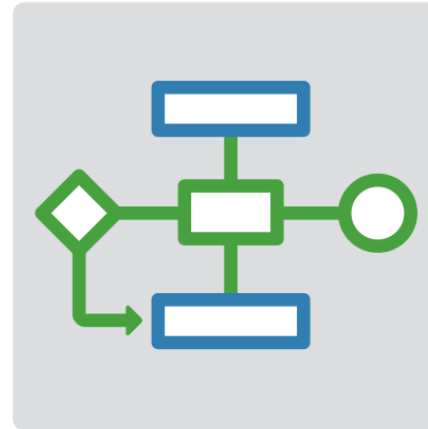

**Support for your
entire workflow**

Platform Productivity



Integrate MATLAB Analytics into Enterprise Applications

Deploy MATLAB algorithms without recoding or creating custom infrastructure

- Develop clients for MATLAB Production Server in any programming language that supports HTTP using RESTful API and JSON

R2016a

- Configure and manage multiple server instances using a web-based interface

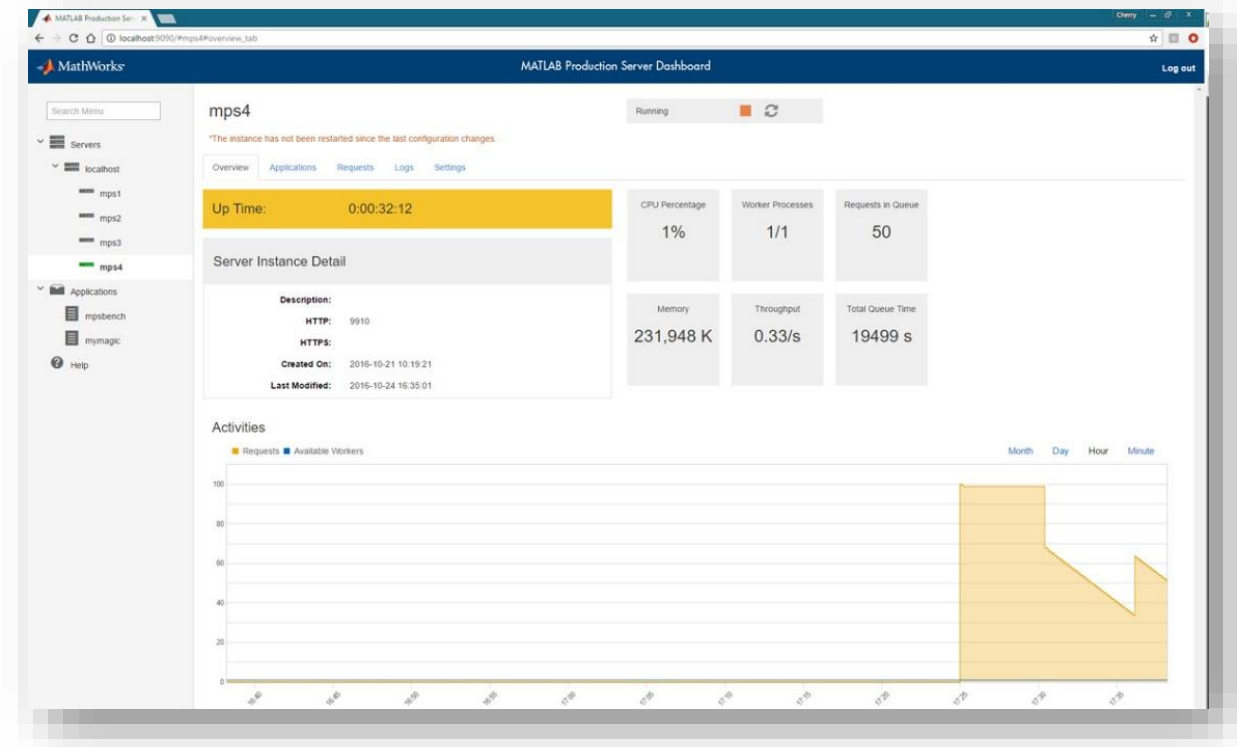
R2017a

Connecting MATLAB Analytics to IoT Systems

Develop analytics and deploy IoT systems

- Quickly collect and analyze IoT data with ThingSpeak and MATLAB
- Develop analytics algorithms using MATLAB and toolboxes
- Deploy on smart devices using code generation and embedded target support
- Deploy at scale on cloud using ThingSpeak and MATLAB Production Server

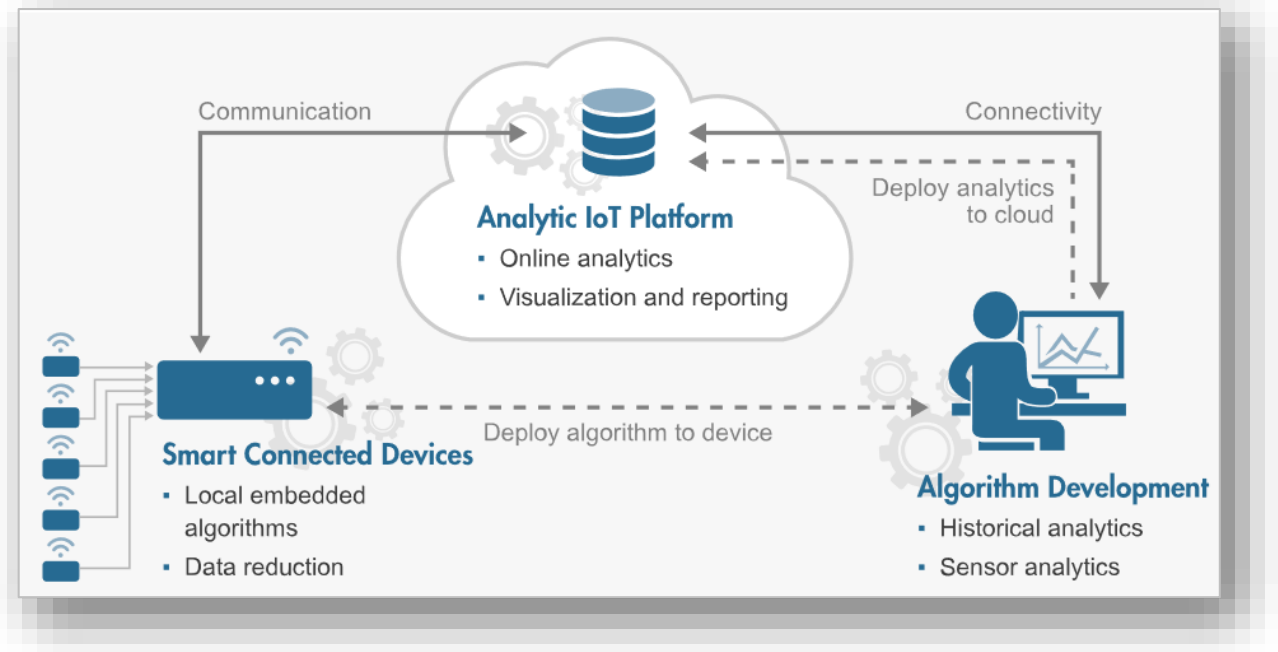

New Hardware Support

Run Simulink models on low-cost hardware devices

- Run Simulink models on Raspberry Pi 3 and Google Nexus devices
- Adds to existing hardware support, including LEGO, Arduino, iPhone, and Android devices

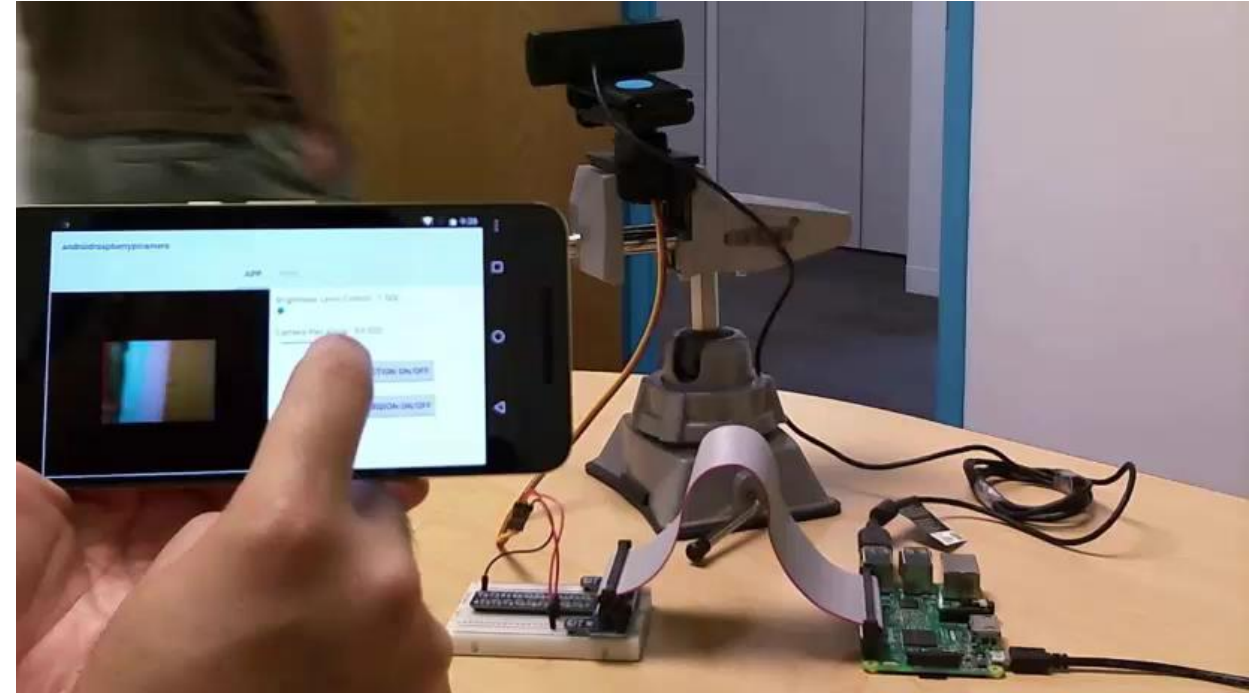

More Connections to 3rd Party Tools

Connect your models to Onshape and DOORS Next Generation

- Convert an Onshape CAD assembly into a Simscape Multibody model
- Link and trace model elements to requirements in DOORS Next Generation

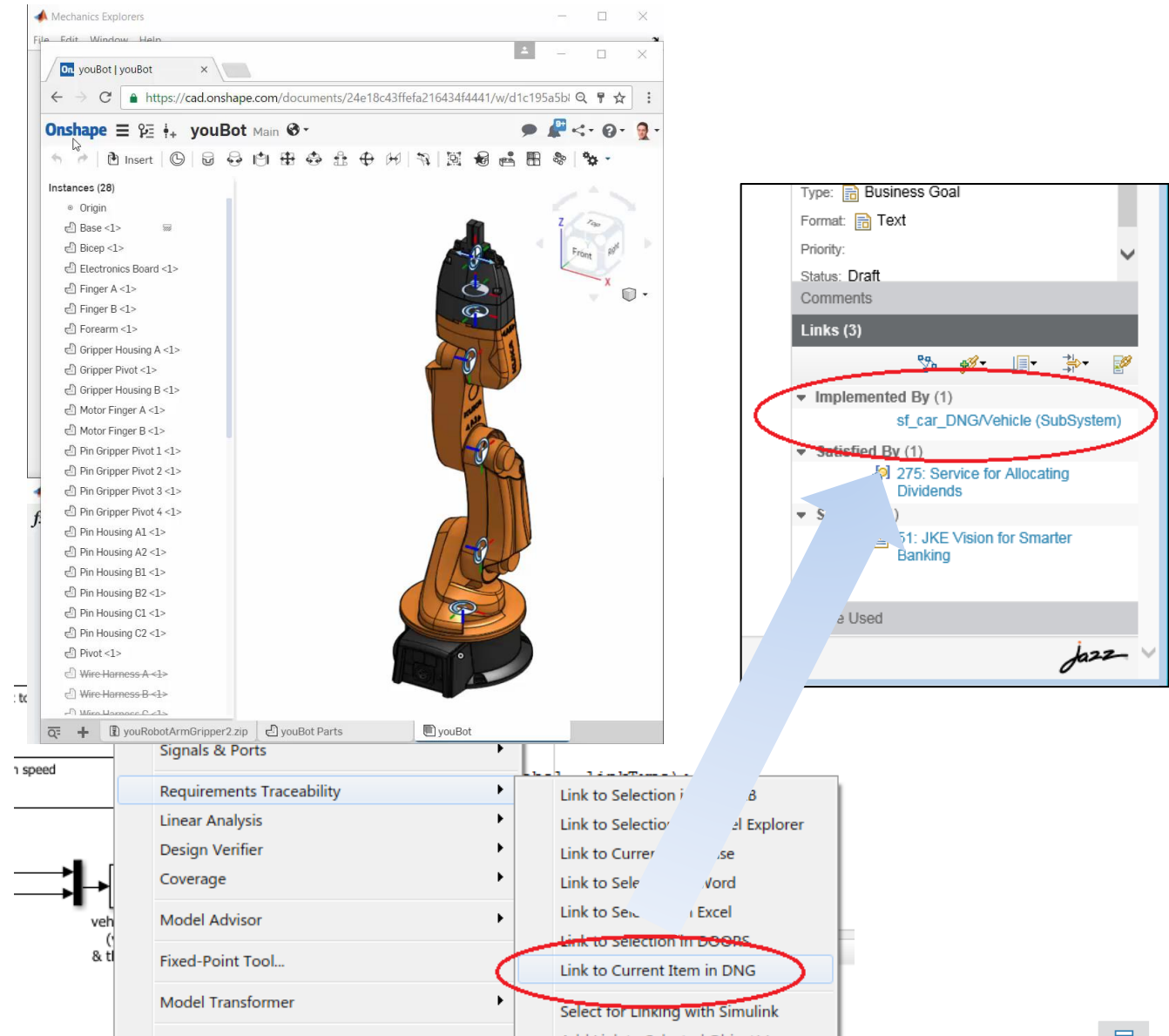

Complying with Safety-Critical Standards

Detect and fix standards compliance issues at design time with edit-time checking

- Quickly address compliance and modeling standards issues before running the model
- For example, check for prohibited blocks or block names
- Especially useful for applications that require compliance to standards such as DO-178, ISO 26262, IEC 62304

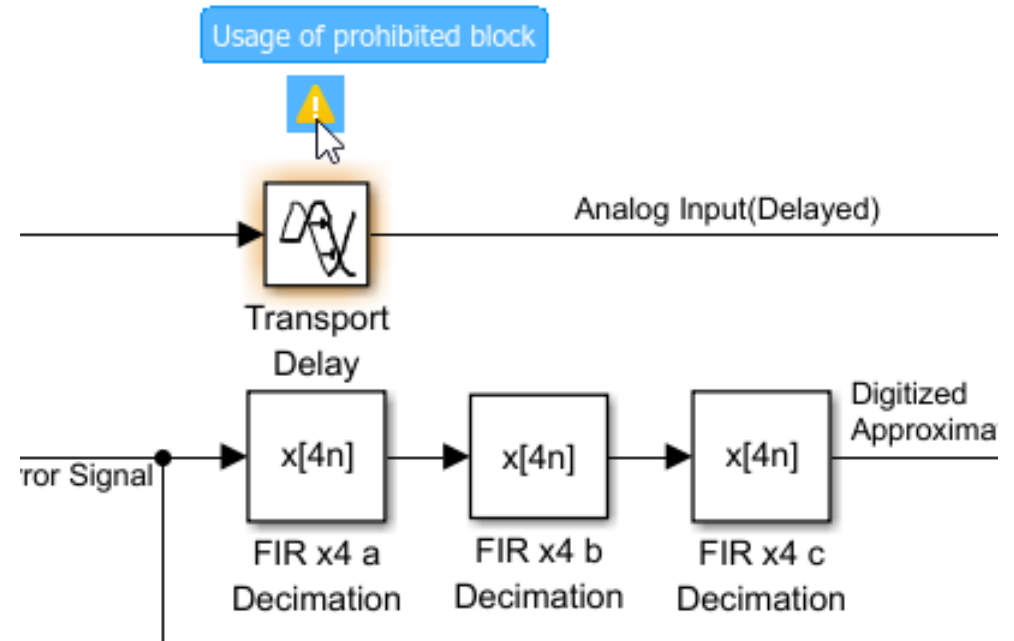

Efficient Code Generation

Improve code quality with clone detection and dynamic memory allocation

- Refactor repeating library patterns and subsystem clones
 - Reduces redundancy
 - Improves reusability
- Generate C code that uses dynamic memory allocation from MATLAB Function blocks
 - Allocate memory as needed at runtime

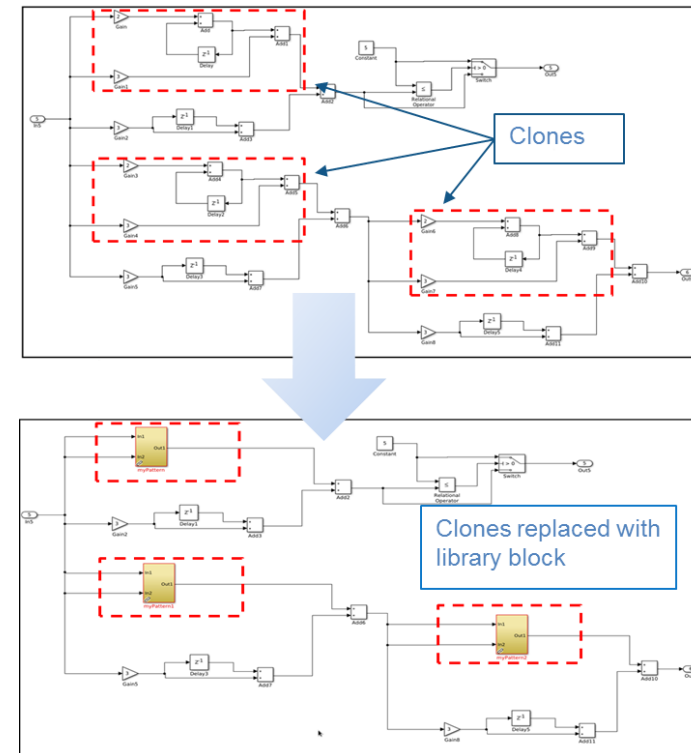

```

118  /* MATLAB Function: '<Root>/MATLAB Function' */
119  /* MATLAB Function 'MATLAB Function': '<S1>:1' */
120  if (!mymdl_DW.p_not_empty) {
121      /* '<S1>:1:4' */
122      /* '<S1>:1:5' */
123      k = mymdl_DW.p->size[0] * mymdl_DW.p->size[1];
124      mymdl_DW.p->size[0] = 1;
125      mymdl_DW.p->size[1] = 0;
126      mymdl_emxEnsureCapacity((emxArray_common_mymdl_T *)mymdl_DW.p, k, (int
127          sizeof(real_T));
128      mymdl_DW.p_not_empty = false;
129  }

```

Floating Point HDL Code Generation

Generate HDL code directly from single-precision floating point Simulink models

- No need to manually convert from floating point to fixed point
- Mix integer, fixed-point, and floating point operations to balance numerical accuracy versus hardware resource usage

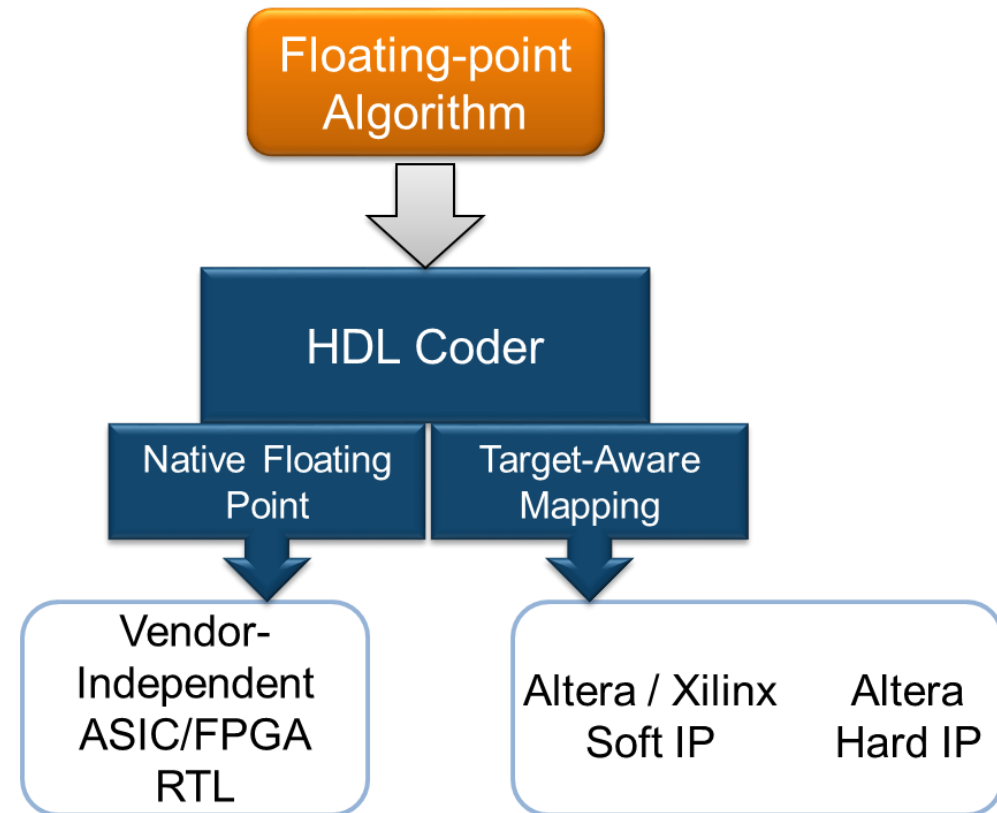

Code Verification

Learn more at this session:

*Verificación de código
generado automáticamente*

Detect and prove the absence of run-time errors in your source code using static analysis

- Identify CERT C violations using defect checkers and coding rules
- Detect security vulnerabilities highlighted by the CERT C standard
- Addresses growing concern over software security with the rise in system connectivity

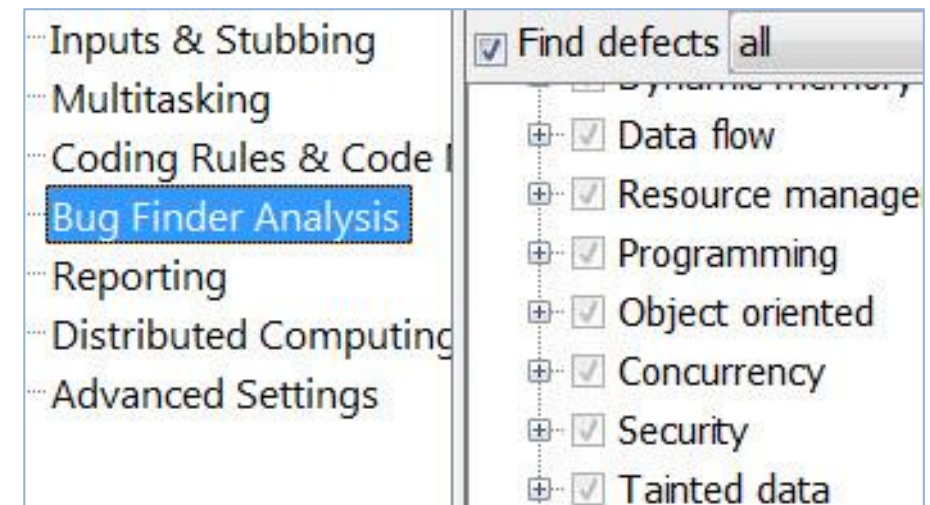

```
if (output v7 >= 0) {
    saved_values[output v7] = s8_ret;
    return s8_ret;
}
return reset temp
```

Assignment to element of static array (int 16): [-32 .. 112]
array size: 127
array index value: [0 .. 555]

CERT C	Description	Polyspace Code Prover
ARR30-C	Do not form or use out-of-bounds pointers or array subscripts	Array access out of bounds

Application Breadth

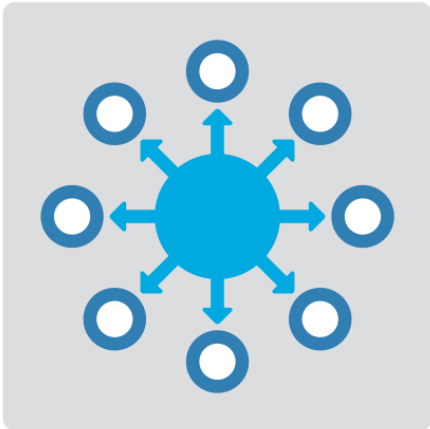

**Products for the
work you do**

Workflow Depth

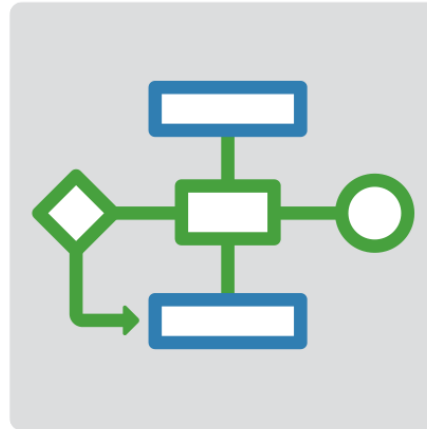

**Support for your
entire workflow**

Platform Productivity



**Getting your work
done faster**

Change the Way You Work in MATLAB

R2016b R2017a

See results together with your MATLAB code in the Live Editor (introduced in R2016a)

- Add equations, images, hyperlinks, and formatted text
- Present, share, and collaborate using interactive documents
- Interactive figure updates
 - Pan , zoom, and rotate axes
 - Interactive plot customization, with MATLAB code generation to automate work
- Interactive equation editor

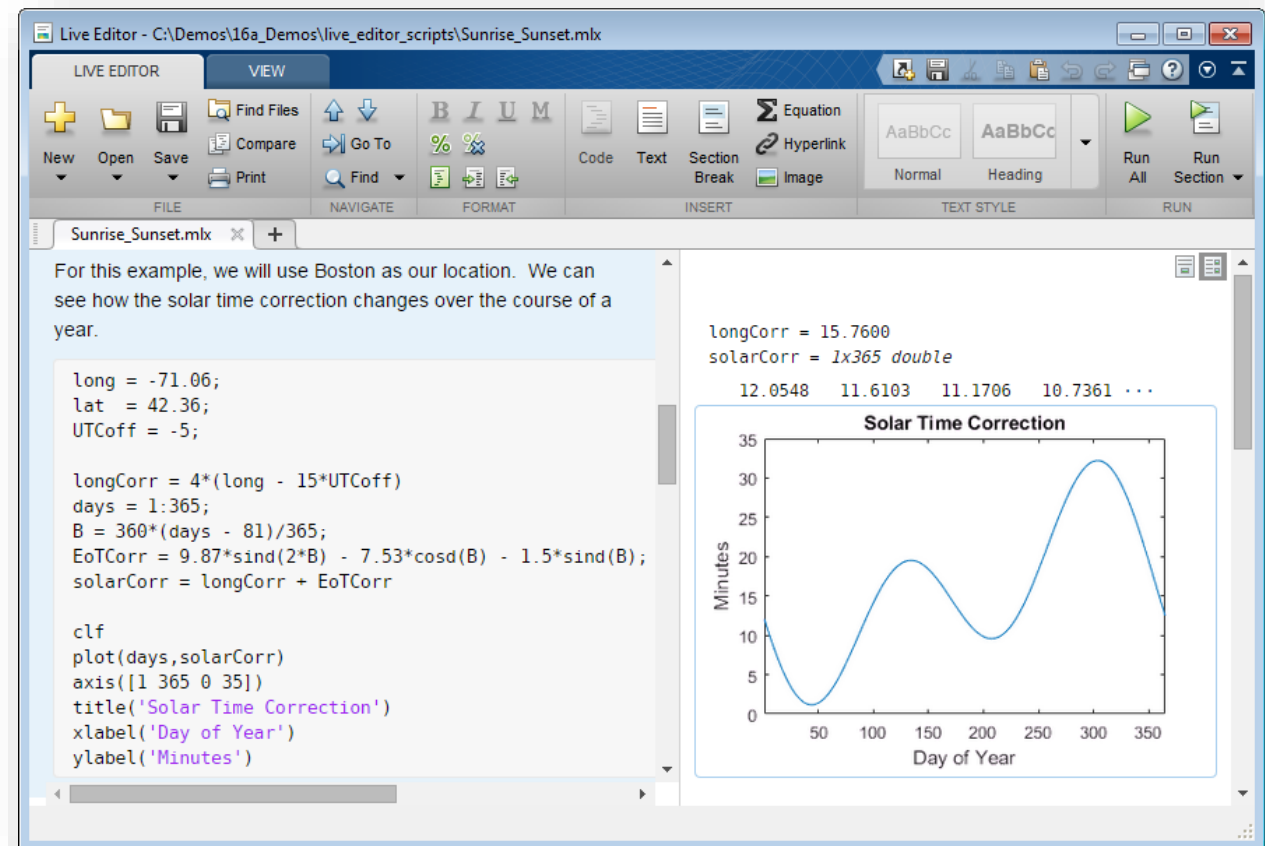

App Designer

R2016b R2017a

Environment for building MATLAB apps (introduced in R2016a)

- Full set of standard user interface components, as well as gauges, knobs, switches, and lamps
- Rich design environment for laying out apps
- Object-based code format for easily sharing data between parts of the app
- Enhancements include:
 - Majority of 2-D plots supported
 - Embed tabular displays using `uitable`
 - Zoom and pan plots in apps

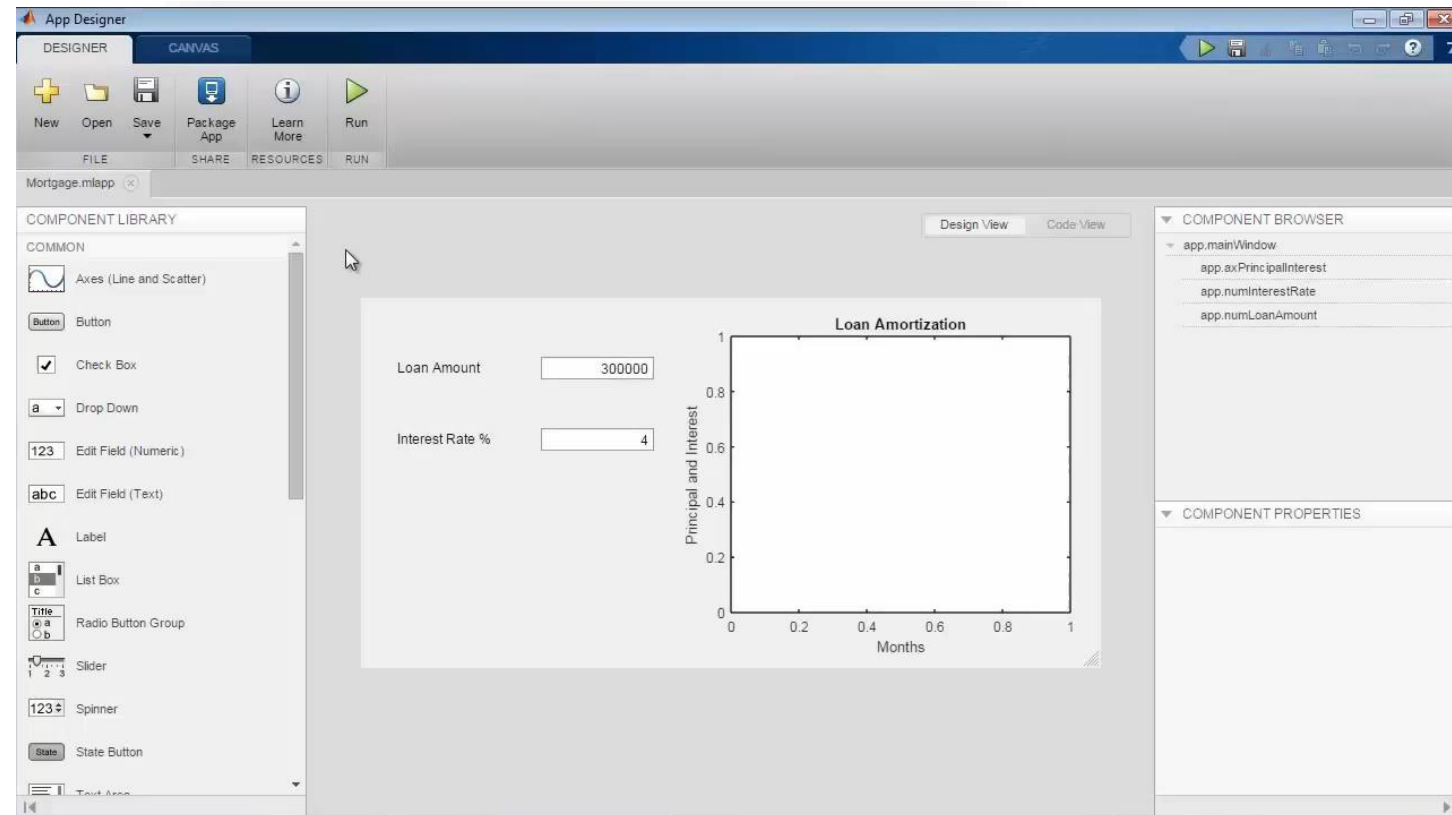

Working with Data Just Got Easier

R2016b R2017a

New data types and functionality for more efficient storage and managing of data

- **timetable** data container (introduced in R2016b)
 - Store time-stamped tabular data
 - Reorganize, evenly space, and align data
- **string** arrays (introduced in R2016b)
 - Memory efficient, faster string operations
 - New functions for common string manipulation
- New capabilities for **preprocessing** data
 - Find, fill, and remove missing data
 - Detect and replace outliers
 - Smooth noisy data

Time	Day	Total	Westbound	Eastbound
06/24/2015 00:00:00	Wednesday	13	9	4
06/24/2015 01:00:00	Wednesday	3	3	0
06/24/2015 02:00:00	Wednesday	1	1	0
06/24/2015 03:00:00	Wednesday	1	1	0
06/24/2015 04:00:00	Wednesday	1	1	0
06/24/2015 05:00:00	Wednesday	7	3	4

```

Command Window
>> s = [string('Square Circle Triangle'); string('Red Blue Green')]
s =
    2x1 string array
    "Square Circle Triangle"
    "Red Blue Green"
>>
>>
>> replace(s, 'Square', 'Rectangle')
ans =
    2x1 string array
    "Rectangle Circle Triangle"
    "Red Blue Green"
fx >>
  
```

Working with Big Data Just Got Easier

R2016b R2017a

Use tall arrays to manipulate and analyze data that is too big to fit in memory

- Tall arrays let you use familiar MATLAB functions and syntax to work with big datasets, even if they don't fit in memory
- Support for hundreds of functions in MATLAB and Statistics and Machine Learning Toolbox
- Works with Spark + Hadoop Clusters

Learn more at this session:
Big Data con MATLAB

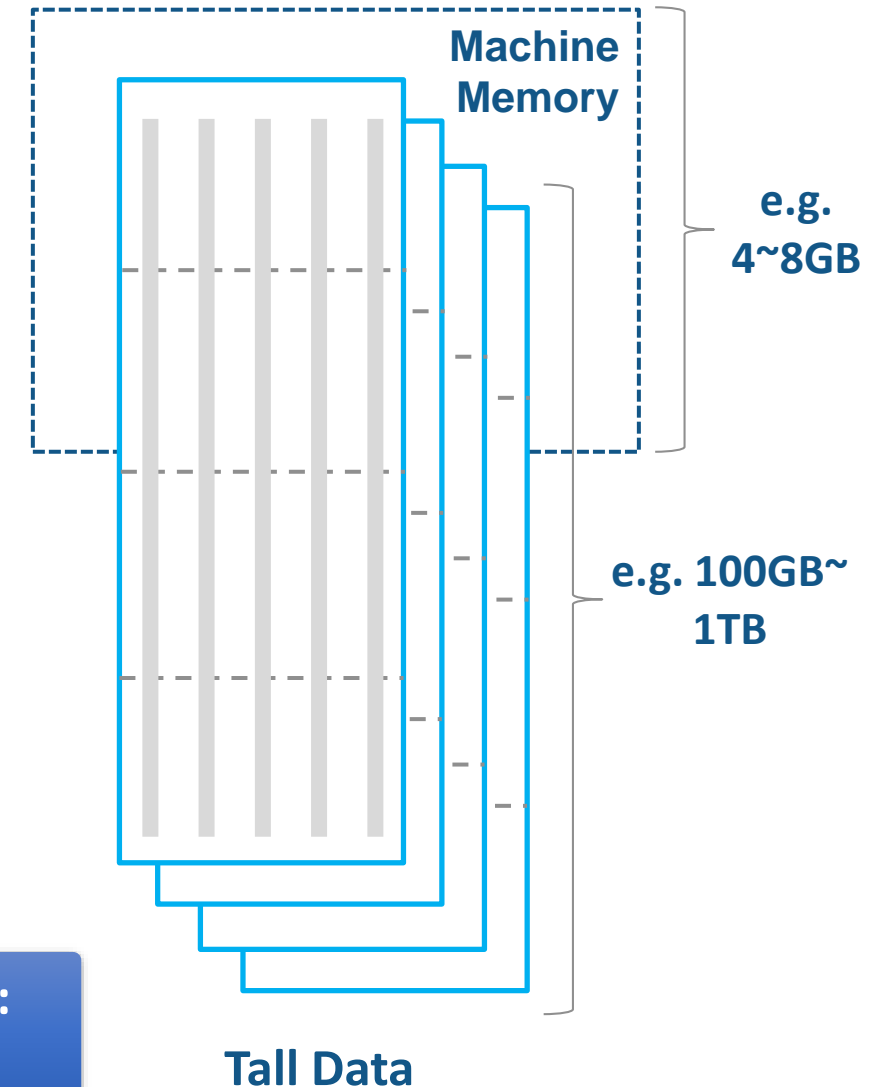

Working with Big Data Just Got Easier in Simulink Too

Stream large input signals from MAT-files without loading the data into memory

- Provides a big data workflow for Simulink simulations
- Use big data in Simulink logging and loading
- Especially useful when running many simulations where data retrieved is too large to fit into memory

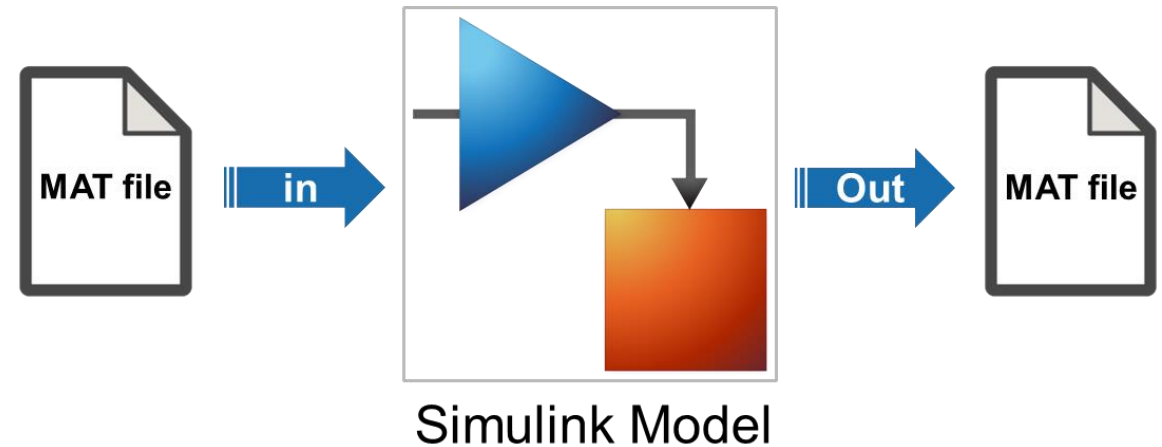

Create Your Models Faster

Use automatic port creation and reduced bus wiring

- Add inports and outports to blocks when routing signals
- Quickly group signals as buses and automatically create bus element ports for fewer signal lines

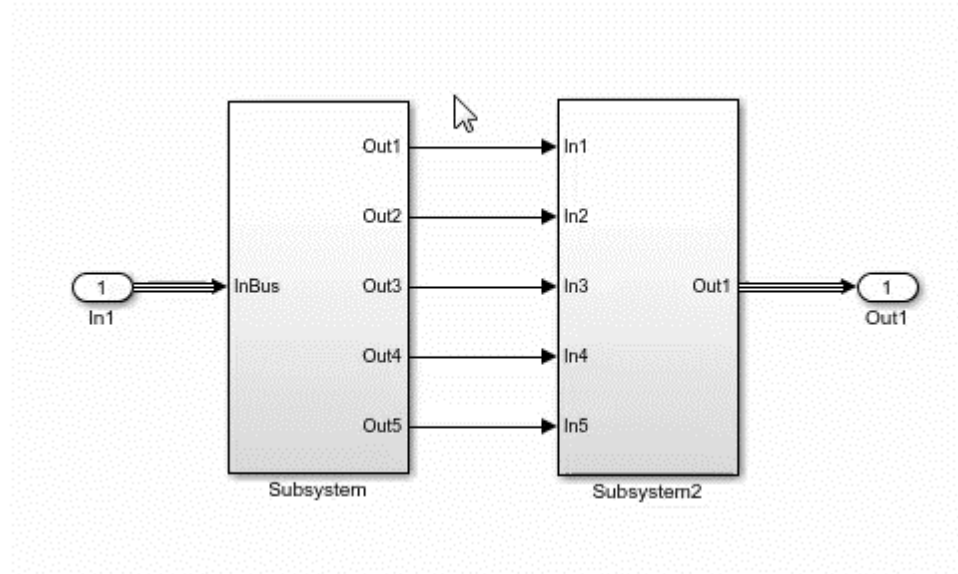
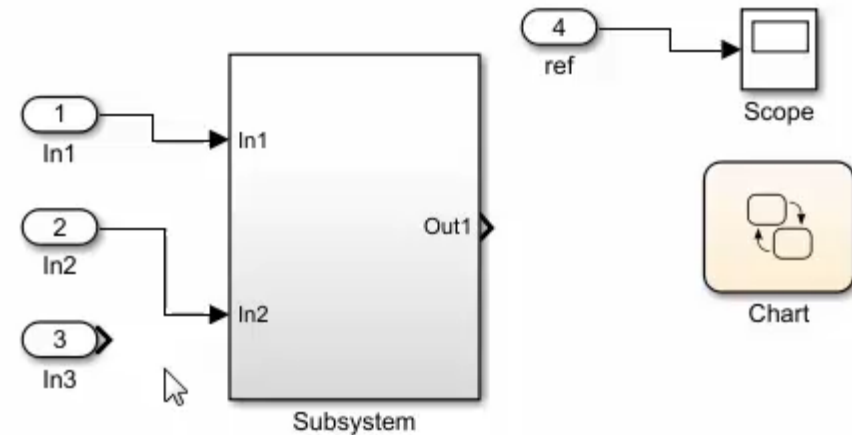

Define your Data Faster

Reduces the need to open separate dialog boxes

- Model and block parameter data is now accessible within the main editor window
- Accessing and defining Stateflow data is also much easier

The screenshot displays the Stateflow editor interface for a Simulink chart named 'slidemo_fuelsys/fuel_rate_control/control_logic'. The main workspace shows a Stateflow chart with several states and transitions. The 'Fueling_Mode' state is expanded, showing sub-states like 'Normal', 'Warmup', 'Rich_Mixture', and 'Single_Failure'. The 'Property Inspector' is open on the right, showing the 'Monitoring' tab for the 'Fuel_Disabled' state. The 'Symbol Manager' is also open, listing symbols like 'es_o', 'es_i', 'max_ego', 'max_press', 'max_throt', 'hys', and 'fuel_mode'. The 'Model Data Editor' is open at the bottom, showing a table of data for the 'fuel_mode' symbol.

Block	Name	Test Point	Stream	Log Data	Path
Pressure Estimation					slidemo_fuelsys/fuel_rate_control/control_logic/Pressure_map_estimate
Throttle					slidemo_fuelsys/fuel_rate_control/control_logic/Pressure_map_estimate
Speed					slidemo_fuelsys/fuel_rate_control/control_logic/Pressure_map_estimate
Throttle Estimation					slidemo_fuelsys/fuel_rate_control/control_logic/Pressure_map_estimate
map					slidemo_fuelsys/fuel_rate_control/control_logic/Throttle_throttle_estimate
Speed					slidemo_fuelsys/fuel_rate_control/control_logic/Throttle_throttle_estimate

Property Inspector

Symbol Manager

Model Data Editor

Simulate your Model Faster

Use the new `parsim` command and JIT acceleration to speed up your simulations

- Directly run multiple parallel simulations from the `parsim` command
- Quickly build the top-level model for improved performance when running simulations in Accelerator mode
- Especially use for Monte Carlo simulations and Design of Experiments

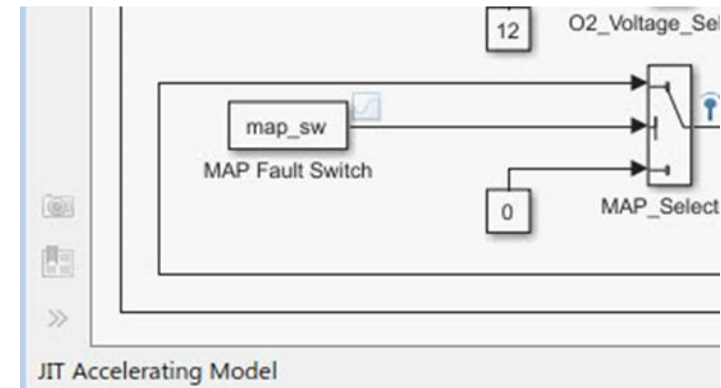
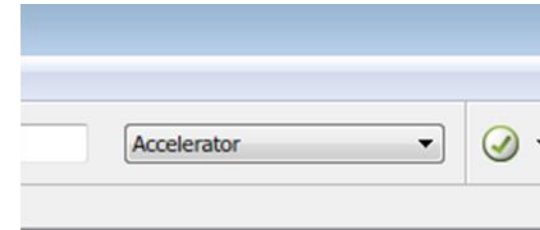
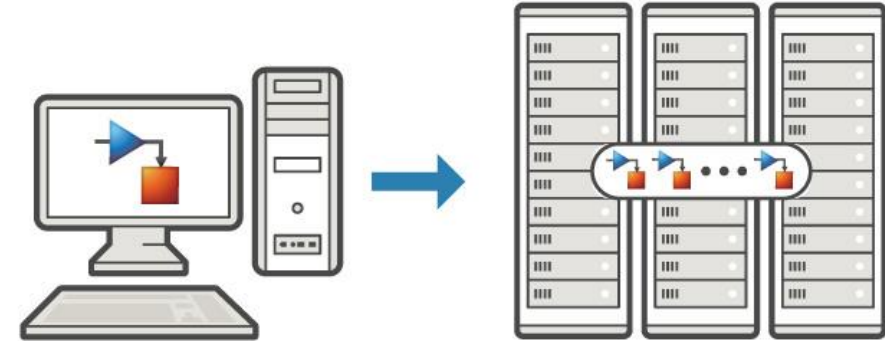

Simulink Project Upgrade

Easily update all the models in your Simulink Project to the latest release

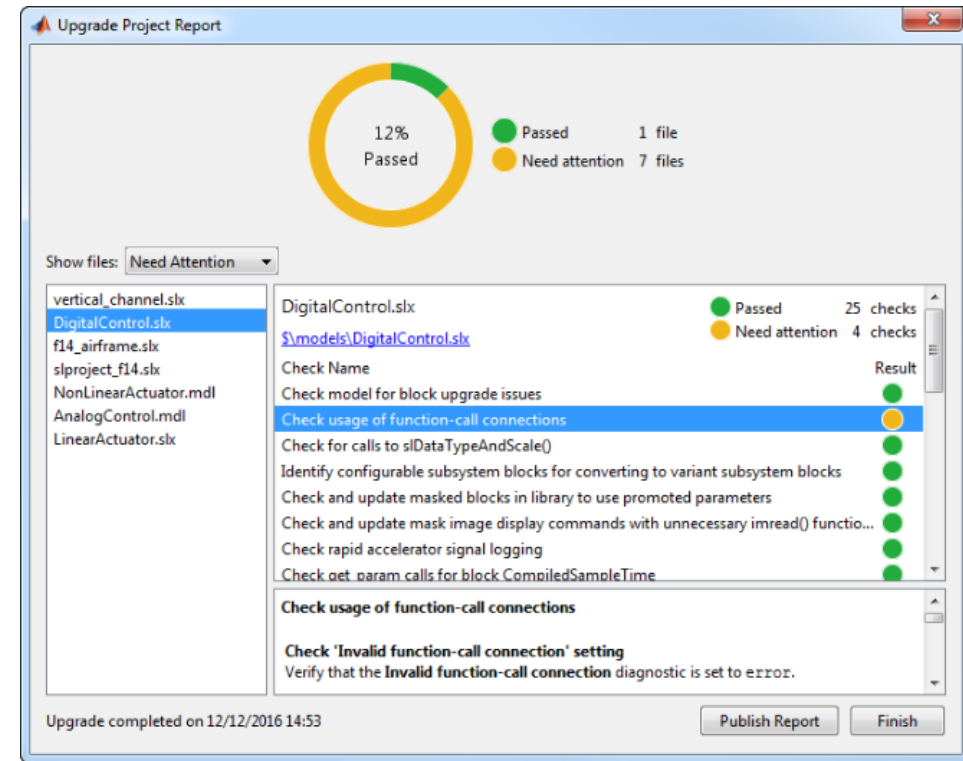
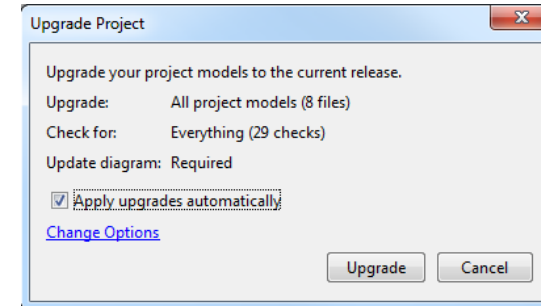

- Avoid the manual process of upgrading one model at a time
- Simulink Project upgrade is an easy to use UI to automate the upgrade process of all the models in a Simulink project
- Fixes are automatically applied and a report gets generated



What's New in MATLAB and Simulink?

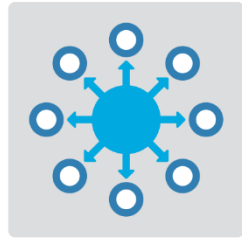

Application Breadth



- Machine learning 
- Deep learning
- Autonomous driving 
- New modeling domains

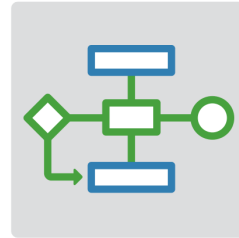

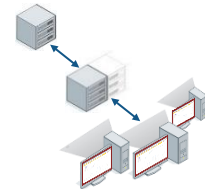
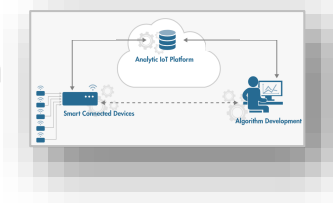
Workflow Depth



- Enterprise applications 
- IoT systems
- 3rd party tool integration 
- Standards compliance
- Code generation and verification 

Platform Productivity

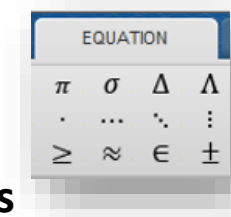

- Live Editor 
- MATLAB Apps 
- New (big) data types
- Modeling enhancements
- Release adoption 

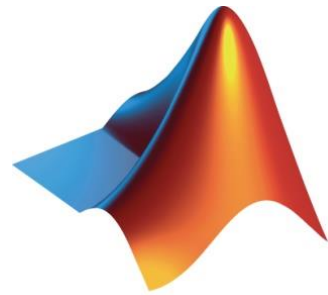

MathWorks®

Accelerating the pace of engineering and science

© 2017 The MathWorks, Inc. MATLAB and Simulink are registered trademarks of The MathWorks, Inc. See www.mathworks.com/trademarks for a list of additional trademarks. Other product or brand names may be trademarks or registered trademarks of their respective holders.